



ASSOCIATION OF
Local Government Ecologists

Mike Oxford

ALGE Project Officer

Chair of BSI Technical Committee on Biodiversity

A British Standard 4 year 2020 target (Hence BS42020)

- Where does it fit in?
- What is it?
- How to use it?

BS42020 ... where does it fit in?

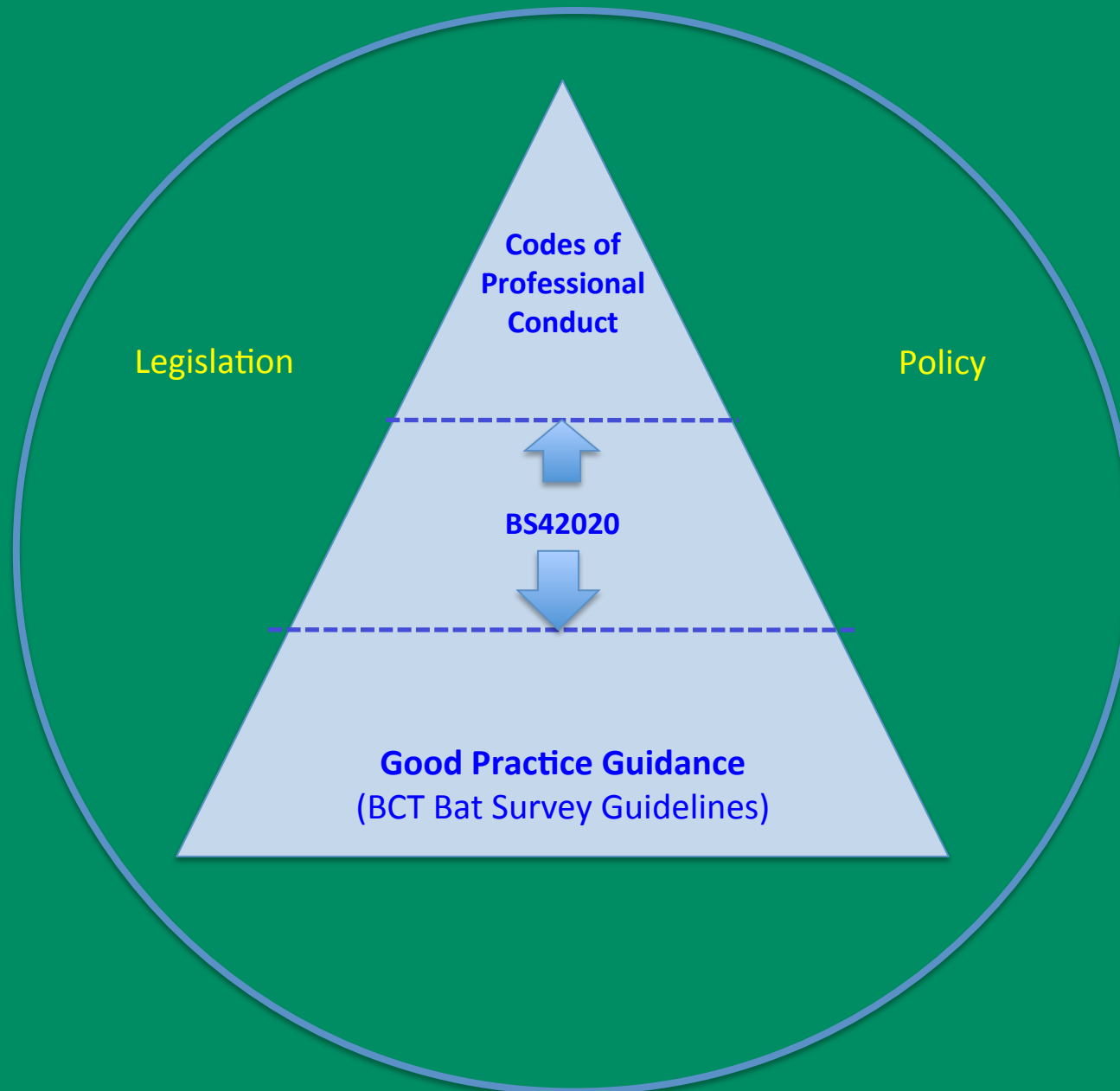

BS42020 ... what is it?

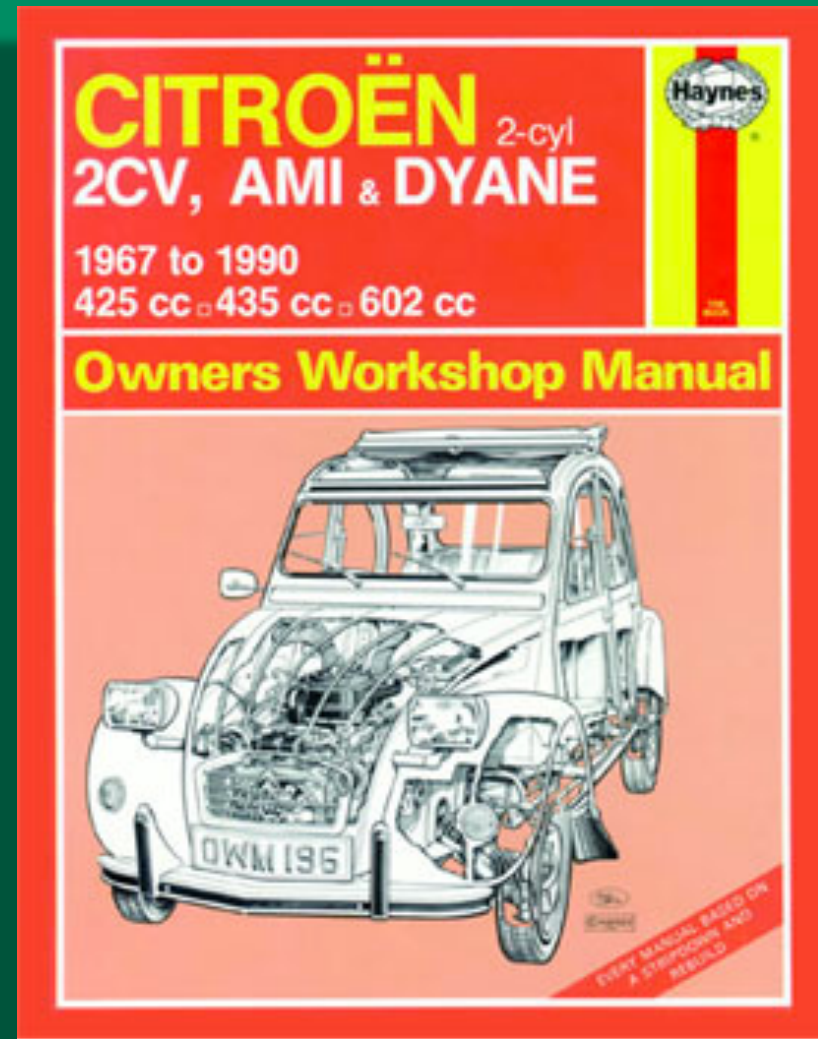
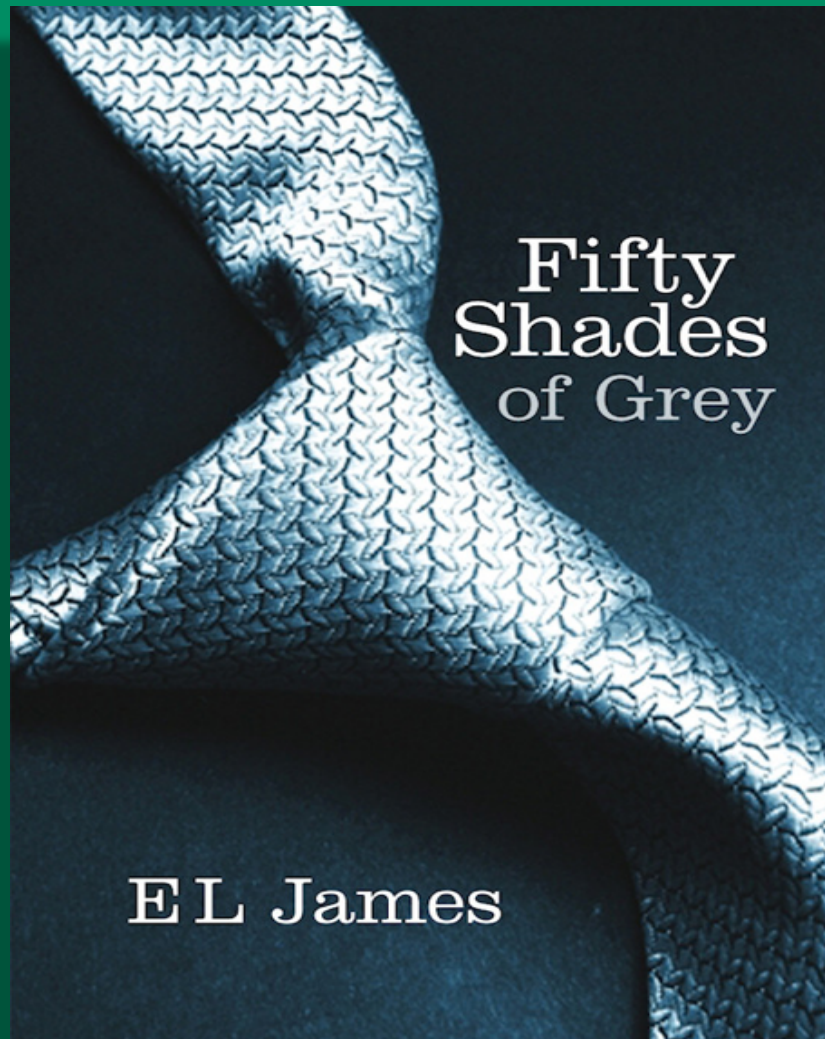

The Concept

Fabulous Professional Practice

- Sound professional ethics
- An interdisciplinary team player
- Appropriate levels of competence (e.g. qualifications and experience)
- Able to exercise judgement in wide variety of situations
- Consistently provides high quality advice and information

Versus Reality !





Biodiversity

Manual for Planning and Development
For all models in the BS 2012 – 2020 series



- Owners Workshop Manual – broken down and taken off the road **NO LONGER FIT FOR PURPOSE**
- Roadside Repairs – running repairs when we are travelling **NEEDS ADJUSTMENT TO CONTINUE**
- MOT Test Checks – Statutory requirements **MUST BE COMPLIANT (*RELIABLE AND TRUSTED*)**
- Service and Repair – periodic routine inspection and maintenance **KEEPS EVERYTHING THAT'S ALREADY WORKING RUNNING SMOOTHLY**

What' the problem ?

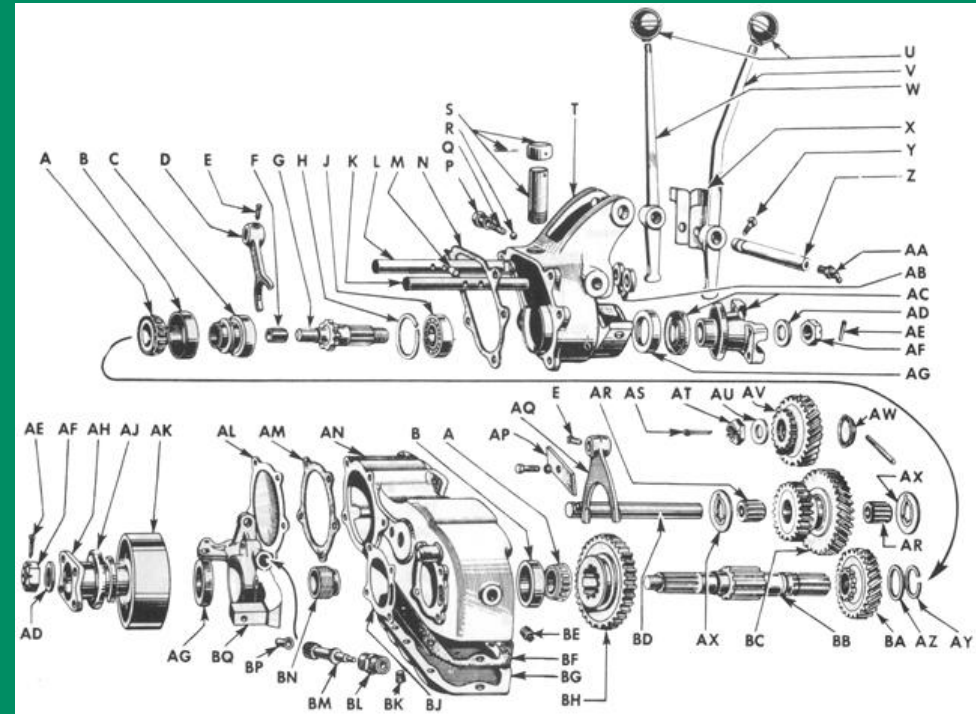

It looks OK on the Outside !

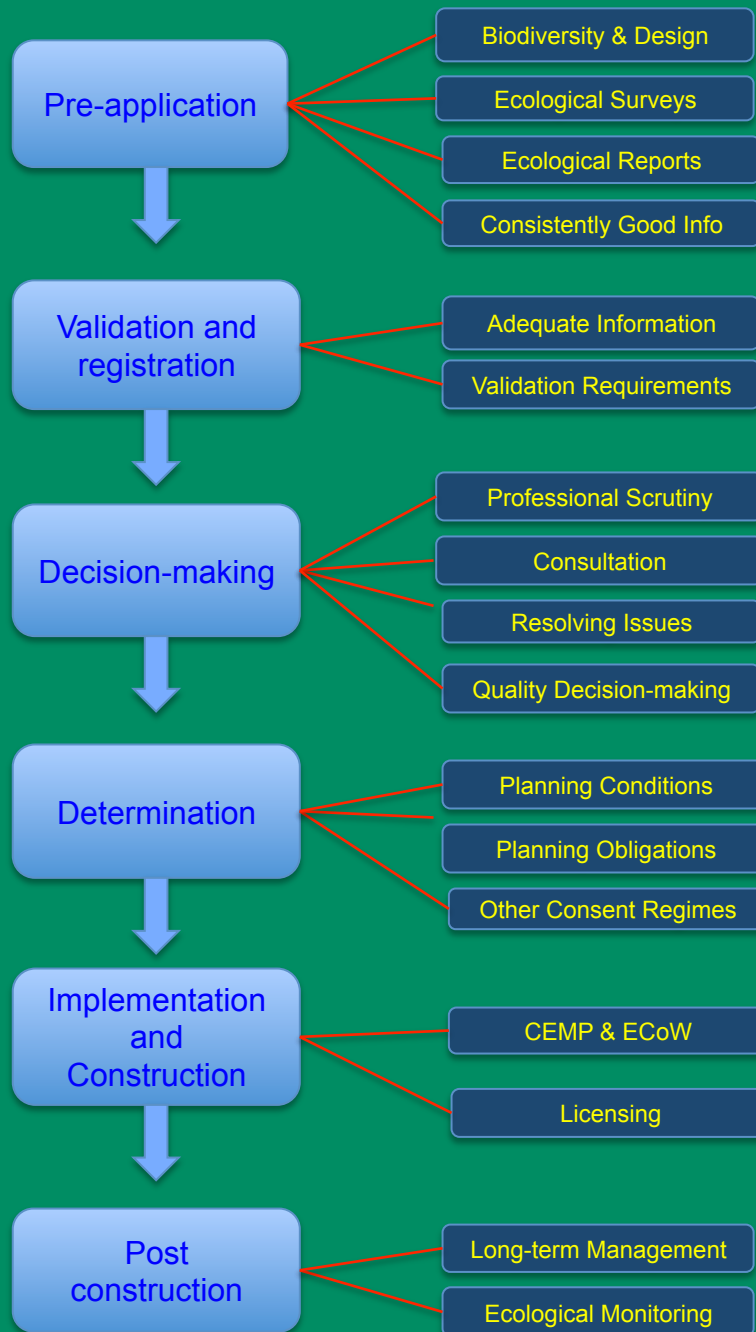

BS42020
Recognises
Information is
collected handled
and acted upon
By different
professionals
at different stages
of the planning
process

Key Elements of BS42020

- Specifications for required standard of ecological surveys and reports
- Registration and validation (the benefit of validation requirements)
- Decision-making
 - issues to consider
 - Scrutiny
 - Consultation
 - Resolving outstanding issues
- Planning consent
 - Conditions
 - Obligations
 - EPS licences
- Compliance during construction (construction environment. management plans)
- Long-term management
- Ecological Monitoring
- Annex D Model planning conditions to address biodiversity issues



ASSOCIATION OF
Local Government Ecologists

SURVEY of ENGLISH PLANNING AUTHORITIES

Ecological Competence and Capacity

What is Needed to Deliver Statutory Obligations?

Two ALGE Surveys During 2013

- Survey of LPA ecologists
- Survey of LPA planners
- Based on the CIEEM Professional Competency Framework

CIEEM Competency Framework

- 4 levels of competence
- 14 competence themes
- Technical and transferable skills/knowledge

Competency Levels

| Category | Definition |
|---------------|---|
| Basic | Has a basic knowledge with a simple understanding of terminology and concepts. Has some experience of practical application. Would be able to carry out standard activities under supervision. |
| Capable | Has the knowledge and experience essential to carry out standard activities unsupervised confidently and consistently. Is likely to need to seek advice before carrying out complex or non-standard activities. |
| Accomplished | Has the knowledge and experience of this topic to carry out complex, specialist or non-standard activities confidently and consistently. Is aware of alternative options and approaches and can provide guidance, instruction and advice to others on this topic. |
| Authoritative | Is widely recognised as an authority, both by others within the organisation and/or by external peers, for the knowledge and experience they demonstrate on the topic. |

Competency Levels

| Category | Definition |
|---------------|--|
| Basic | Has a basic knowledge with a simple understanding of terminology and concepts. Has some experience of practical application. Would be able to carry out standard activities under supervision. |
| Capable | Has the knowledge and experience essential to carry out standard activities unsupervised confidently and consistently. Is likely to need to seek advice before carrying out complex or non-standard activities. |
| Accomplished | Has the knowledge and experience of this topic to carry out complex, specialist or non-standard activities confidently and consistently. Is aware of alternative options and approaches and can provide guidance, instruction and advice to others on this topic. |
| Authoritative | Is widely recognised as an authority, both by others within the organisation and/or by external peers, for the knowledge and experience they demonstrate on the topic. |

Technical Themes

- Ecological Surveying
- Environmental Management
- Environmental Assessment
- Environmental Governance, Legislation & Policy
- Scientific Method
- Consultation and Engagement
- Public Awareness and Education

Transferable Themes

- Professional Conduct
- Business Management
- Project Management
- Information Management
- People Management
- Self Management
- Health and Safety

Subthemes

| | |
|--------------------------|--|
| Ecological Surveying | Survey design |
| | Survey planning and fieldwork skills |
| | Species identification |
| | Species handling |
| | Habitat survey and assessment |
| | Physical environment survey and assessment |
| Environmental Management | Habitat and/or species management |
| | Sustainable environmental design |
| | Environmental compliance |
| | Biosecurity |
| Environmental Assessment | Strategic Environmental Assessment |
| | Environmental Impact assessment |
| | Ecological Impact Assessment |
| | Habitat Regulations Assessment, Appropriate Assessment, Natura Impact Statements |
| | Regulatory aspects of environmental assessment |

Subthemes cont.

| | | |
|--------------------------|----------------------------------|--|
| Environmental management | Habitat and species management | <ul style="list-style-type: none"> • <i>Setting objectives for species/habitat management plans.</i> • <i>Developing and implementing (using appropriate techniques and machinery) schemes for habitat management, habitat creation, habitat/species translocation and other mitigation techniques.</i> • <i>Monitoring the impact of habitat/species management.</i> |
| | Sustainable environmental design | <ul style="list-style-type: none"> • <i>Designing and/or implementing effective sustainable environmental management solutions for biodiversity benefit.</i> • <i>Resolving complex or conflicting constraints to achieve positive outcomes for biodiversity.</i> |
| | Environmental compliance | <ul style="list-style-type: none"> • <i>Design and implementation of site-based projects involving interactions with other professional disciplines.</i> • <i>Environmental risk management on sites</i> |
| | Biosecurity | <ul style="list-style-type: none"> • <i>Consideration of biosecurity issues and risks as part of project design.</i> • <i>Development and implementation of biosecurity protocols in accordance with best practice guidelines</i> |

Results from the Ecologists

LPA Ecologists

First Question:

Are there different levels of competence required for dealing with:

- European Sites & Habitat Regulations Assessments
- National Sites & Protected Species
- Local Sites & and other Biodiversity

Technical Theme: *Scientific Method*

European

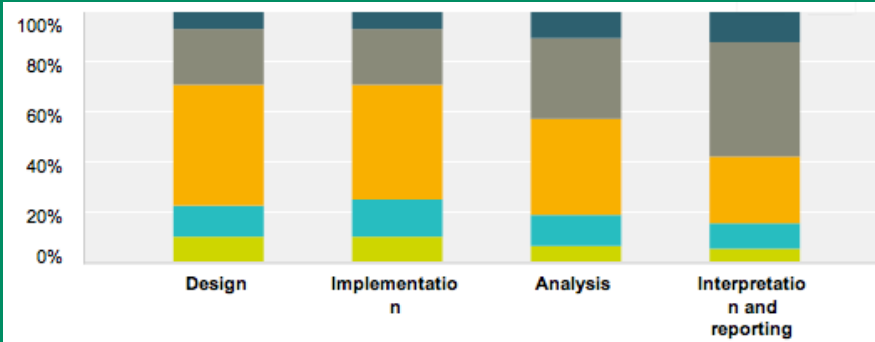

National

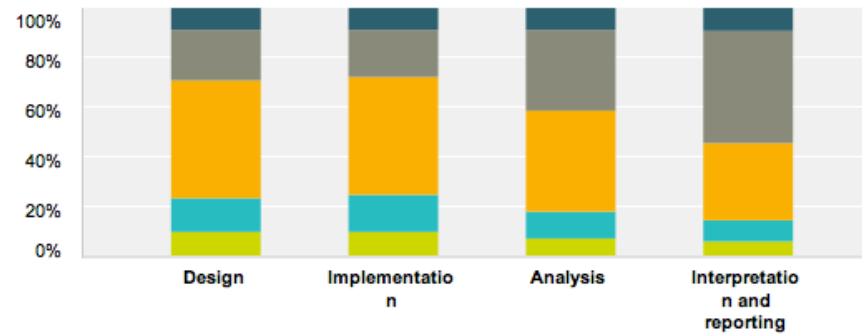

Local

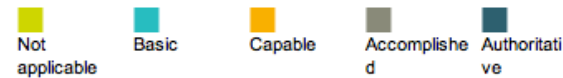
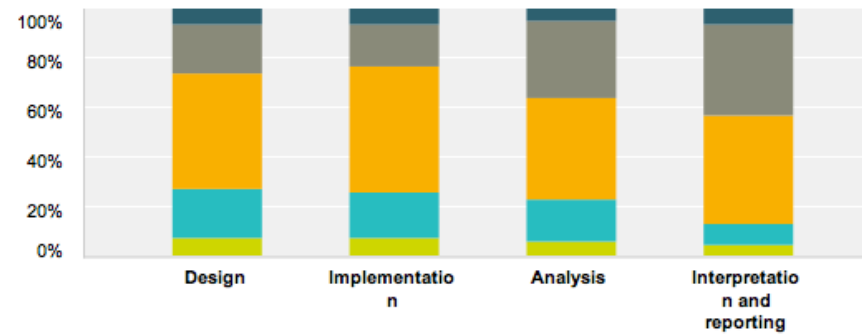

Q6 Ecological Survey

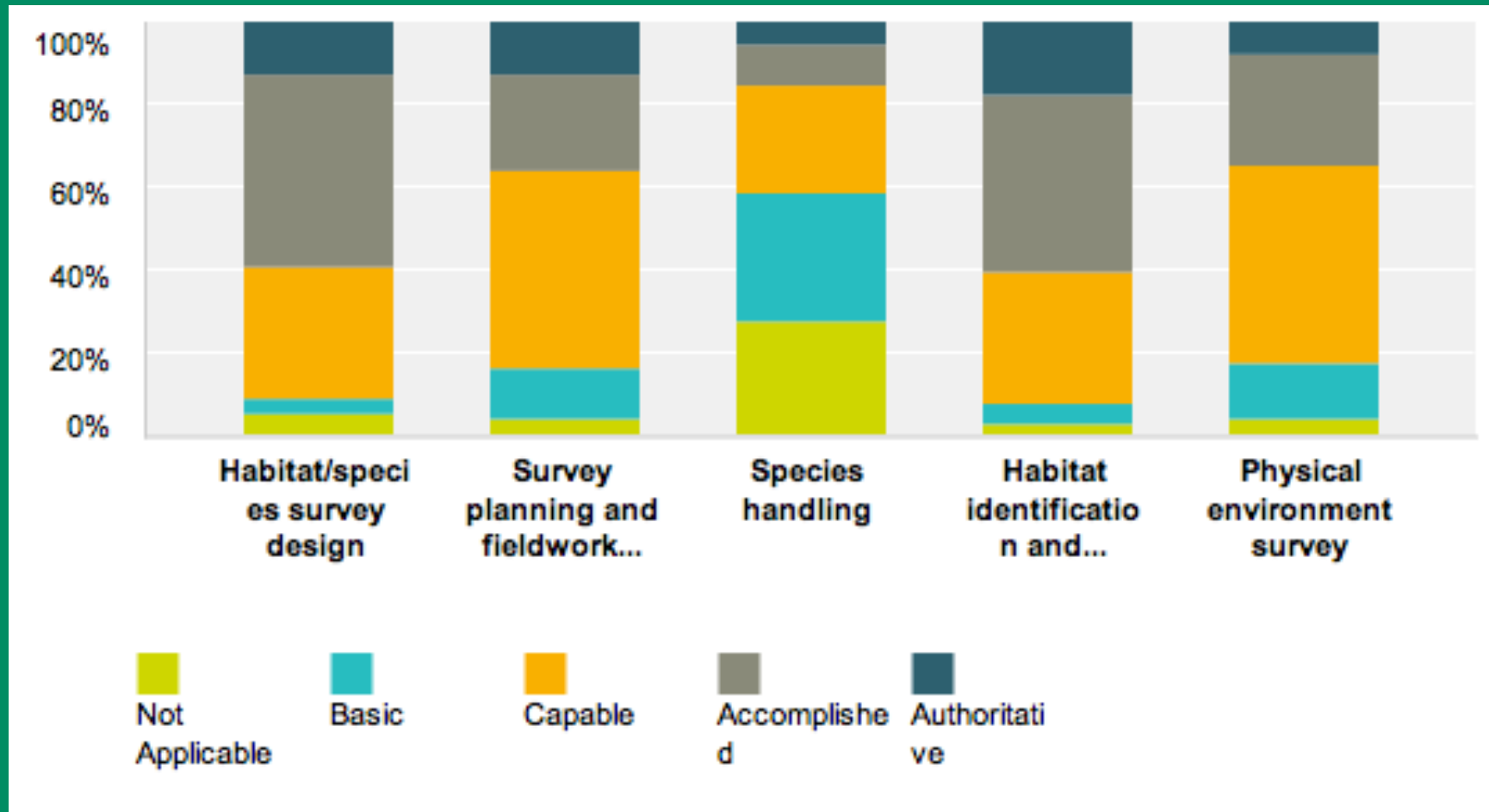

Q7 Environmental Management

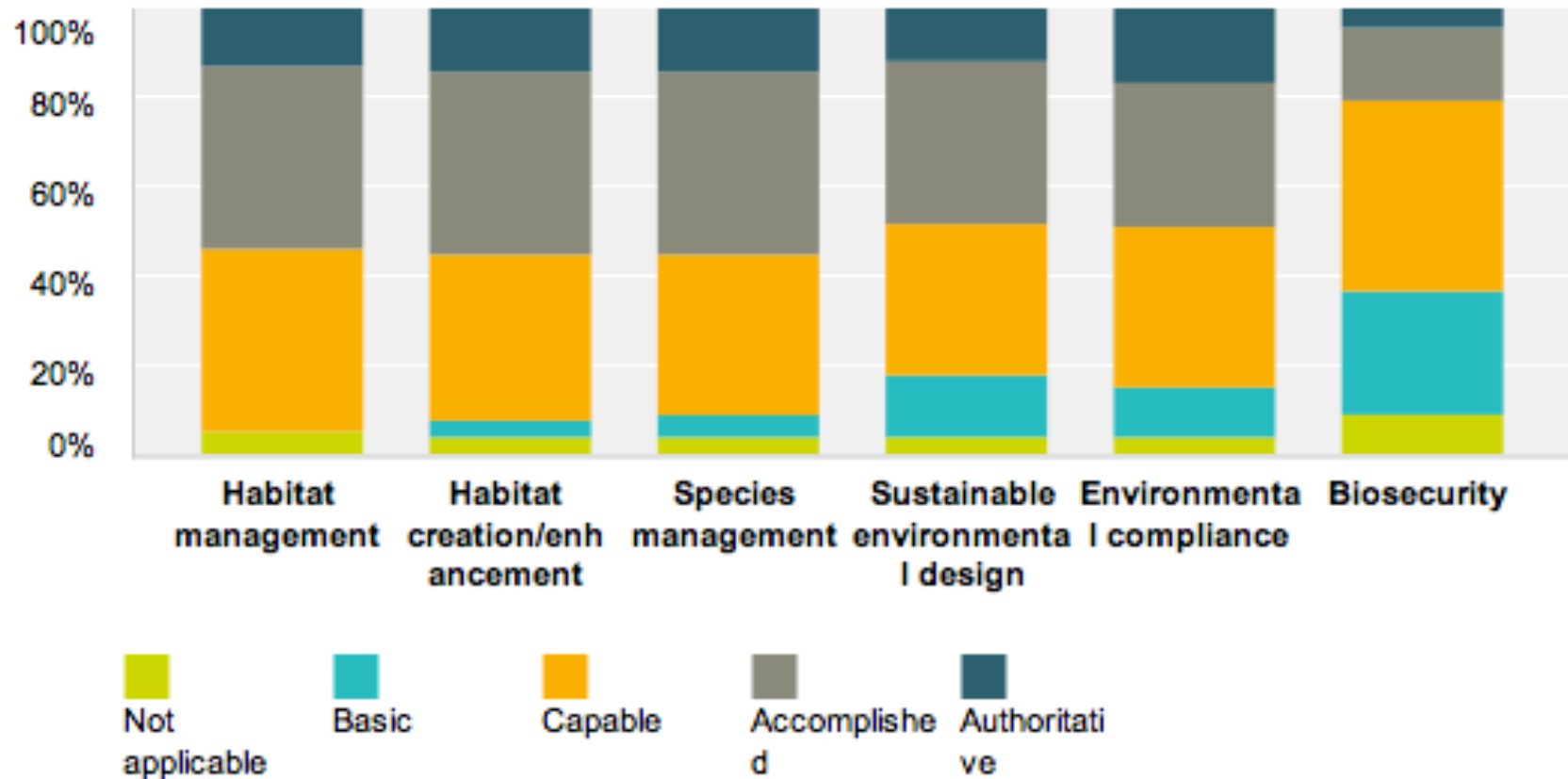

Q8 Environmental Assessments

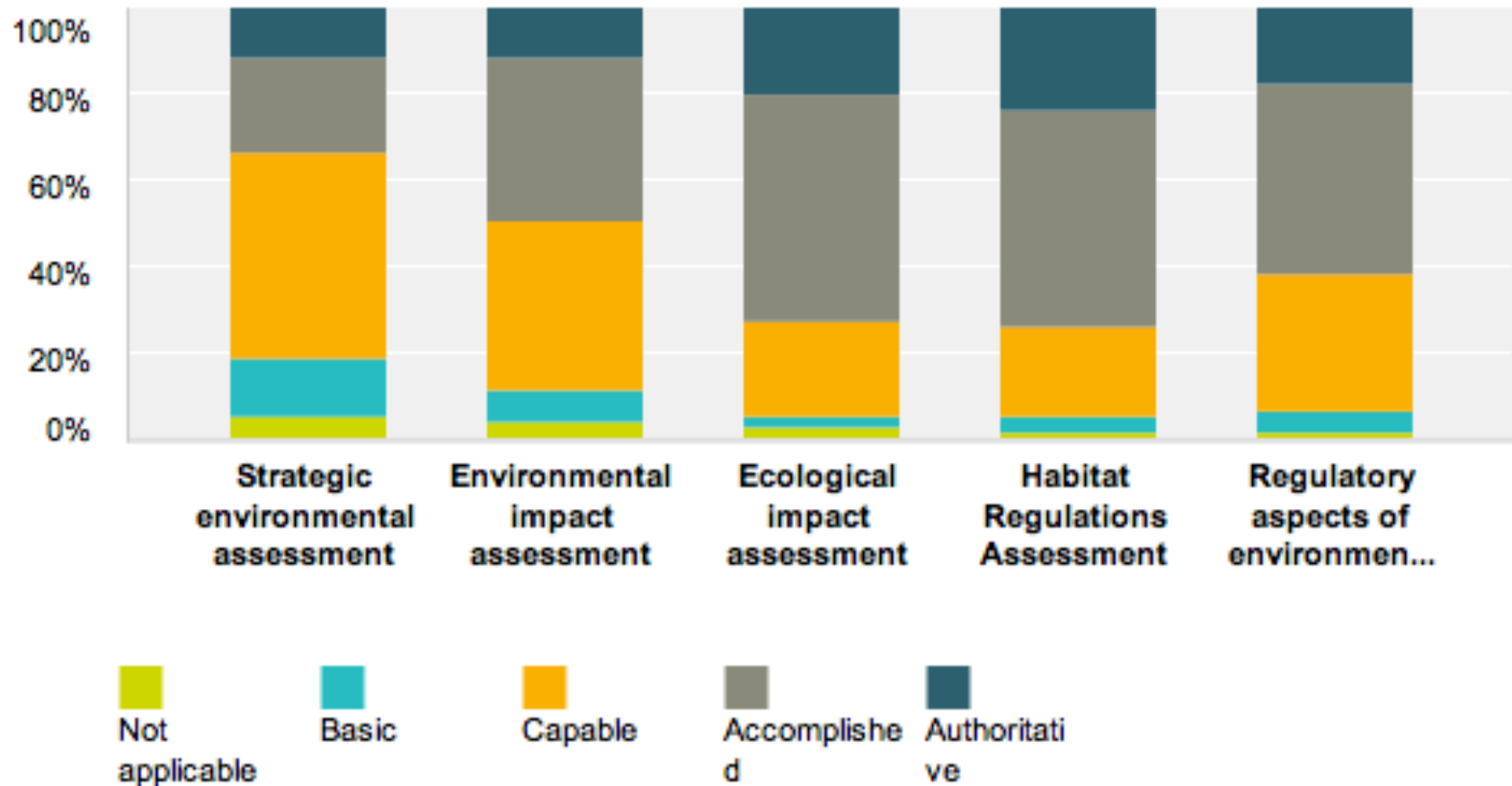

Q9 Environmental Legislation and Policy

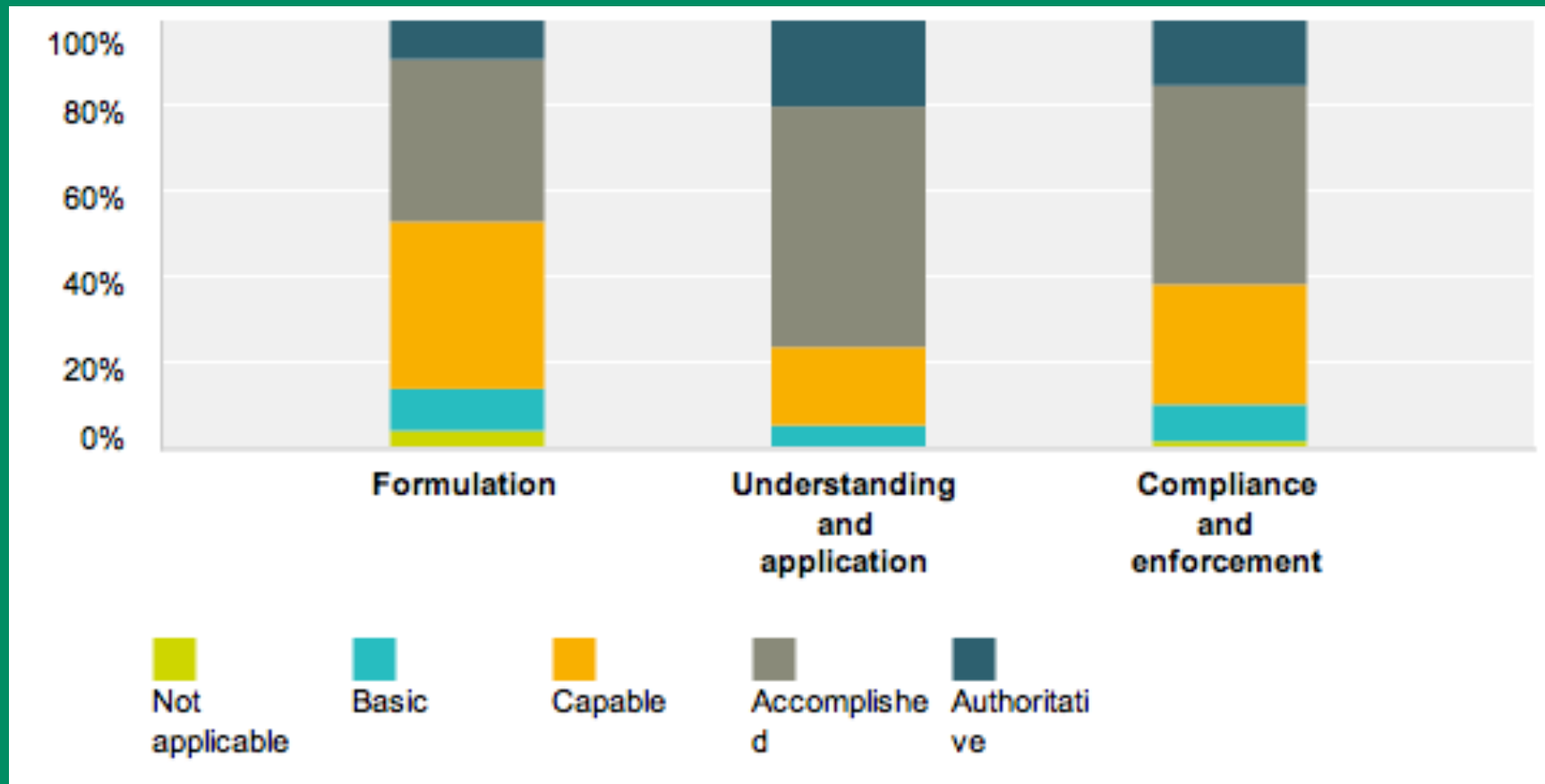

Results from the Planners

How Long Have You Been A Planner?

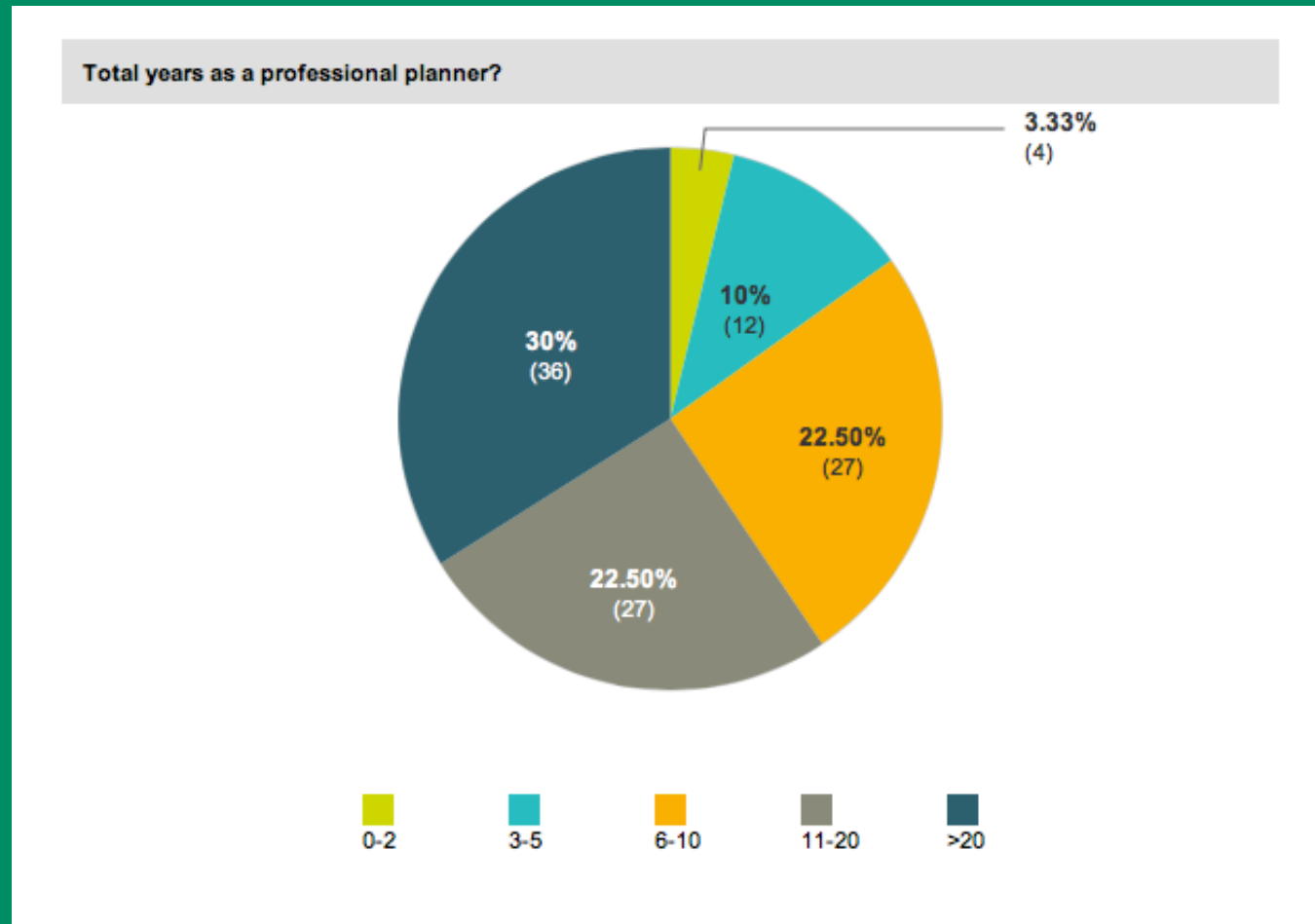

Q 4 How many applications involving:

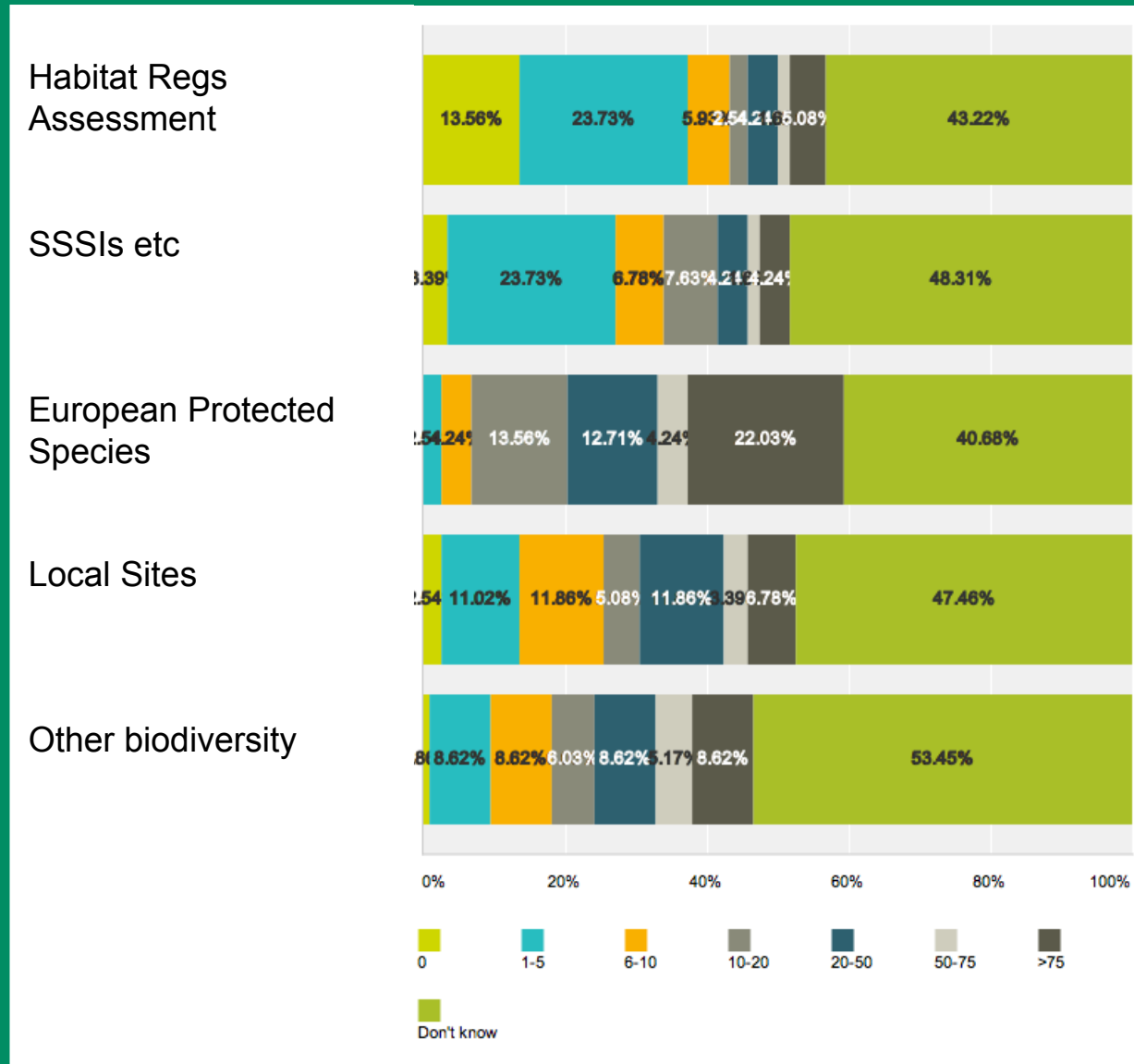

Q5 Access to Ecological Expertise

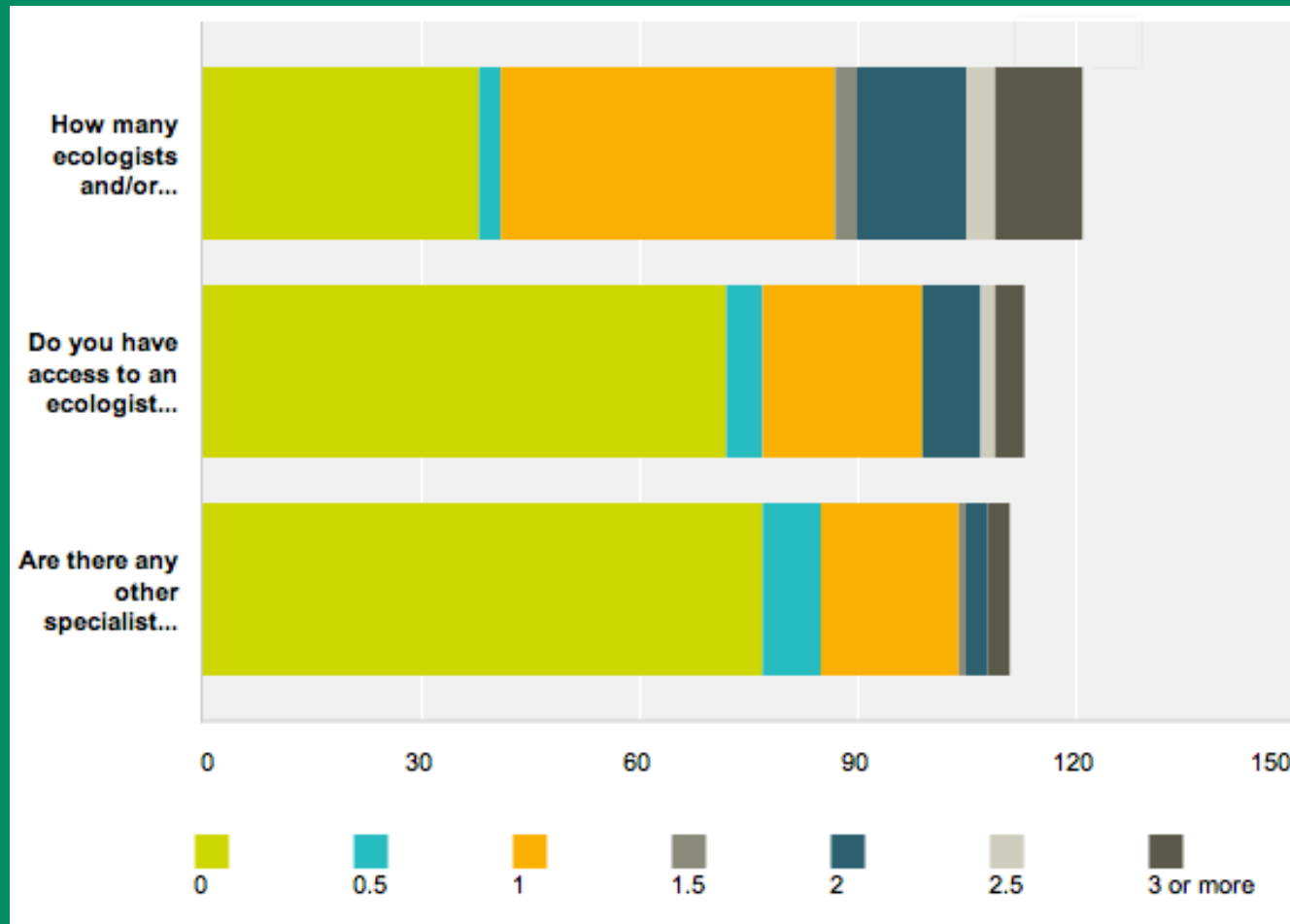

Q7 Preferred Source of Advice



Q8 Who Undertakes HRAs?

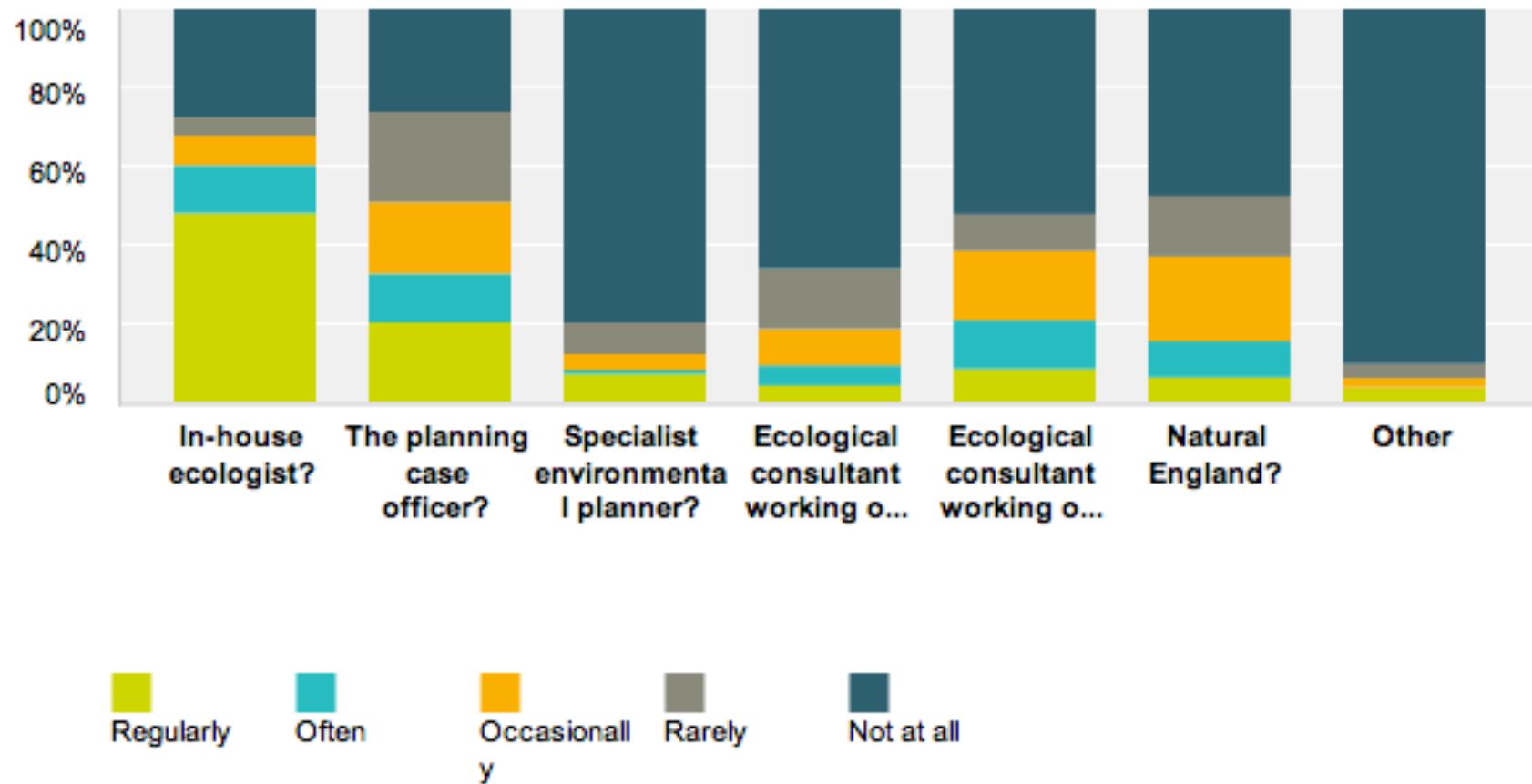

Q9 Scientific Surveys

In order to inform a bona fide opinion what best categorises your knowledge and understanding?

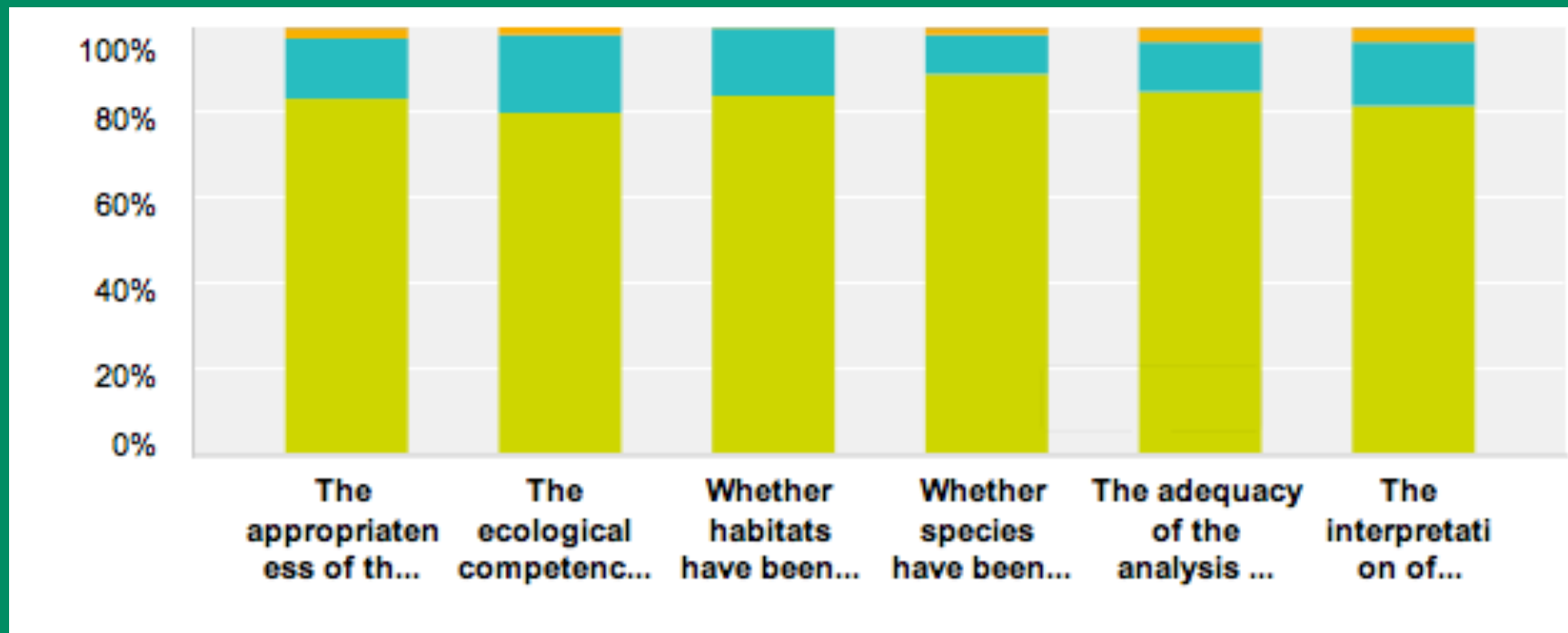

Q10 Ecological Mitigation, Compensation etc

In order to inform a bona fide opinion what best categorises your knowledge and understanding?

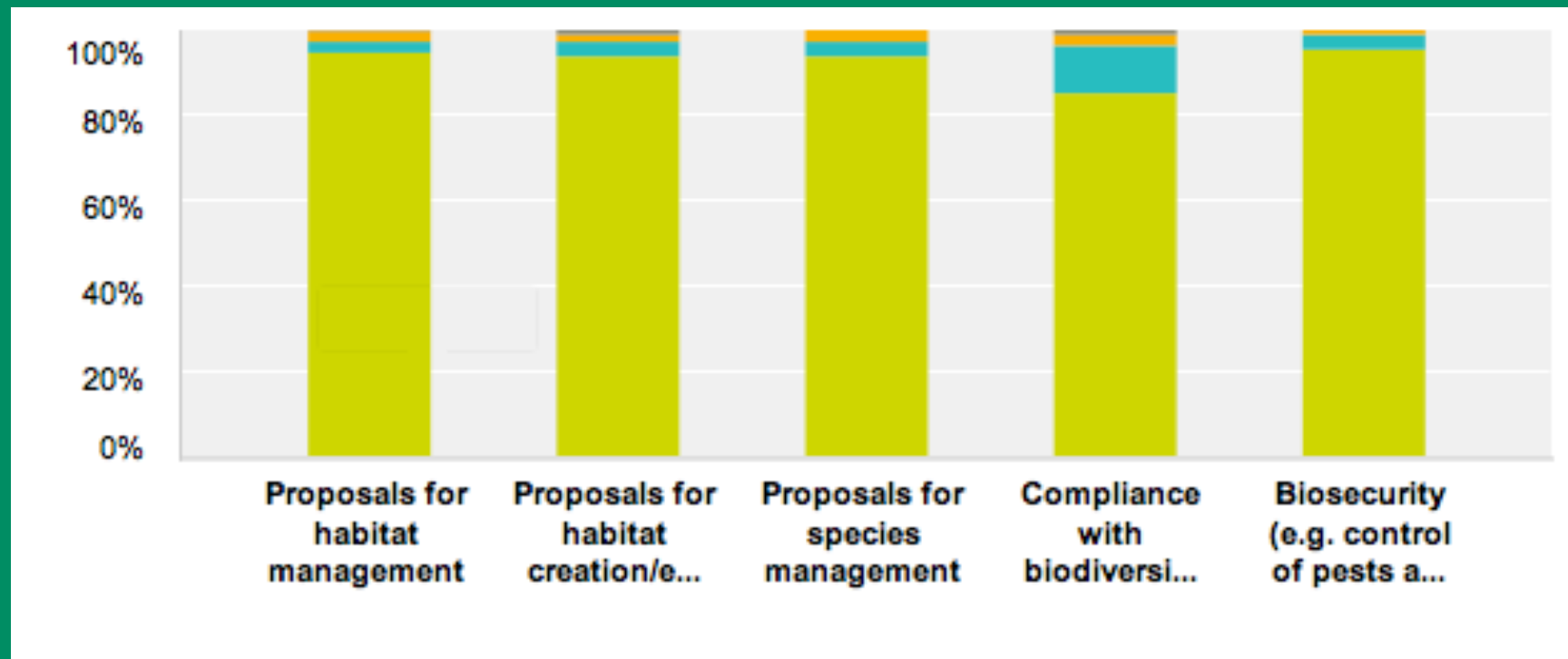

Q12 Bio Leg and Policy

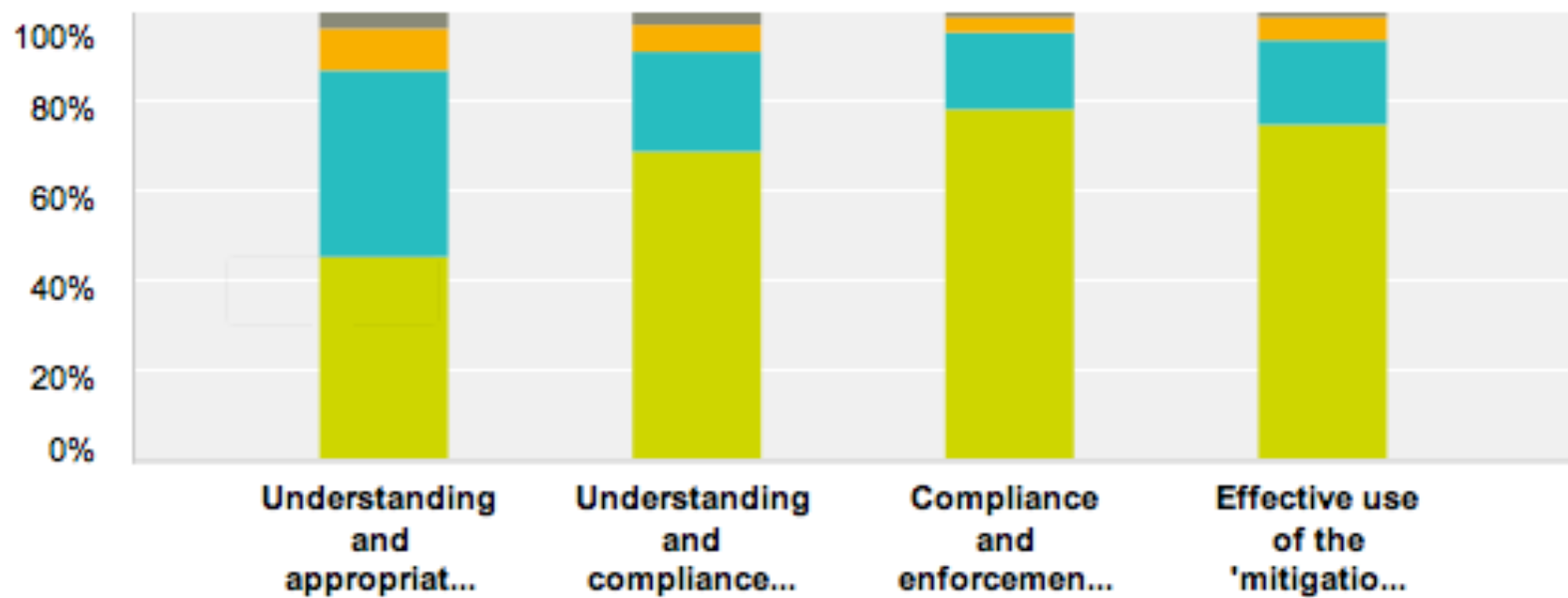

Q11 Environmental Assessment

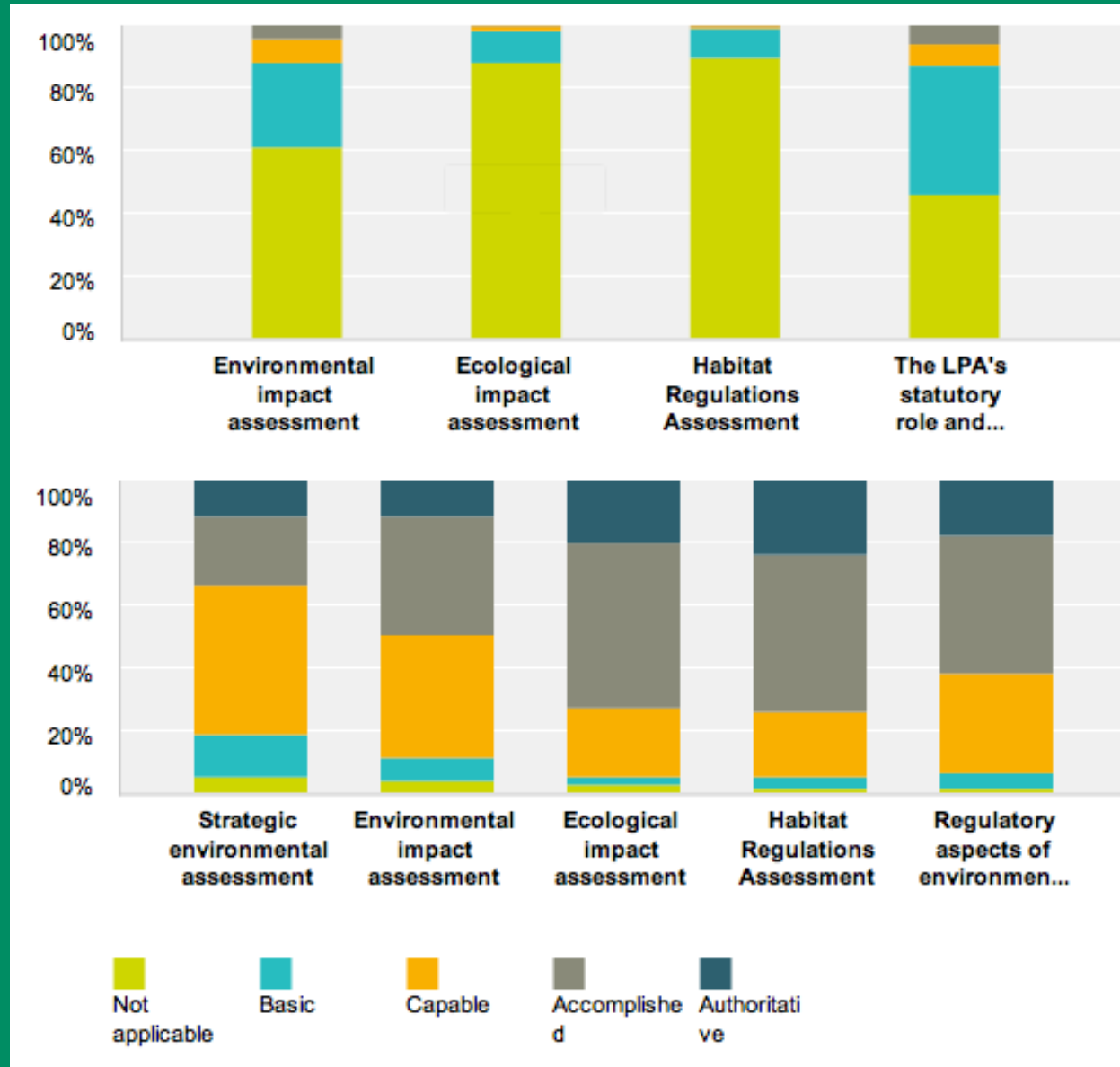

Q14 Planners Training and CPD in Ecology

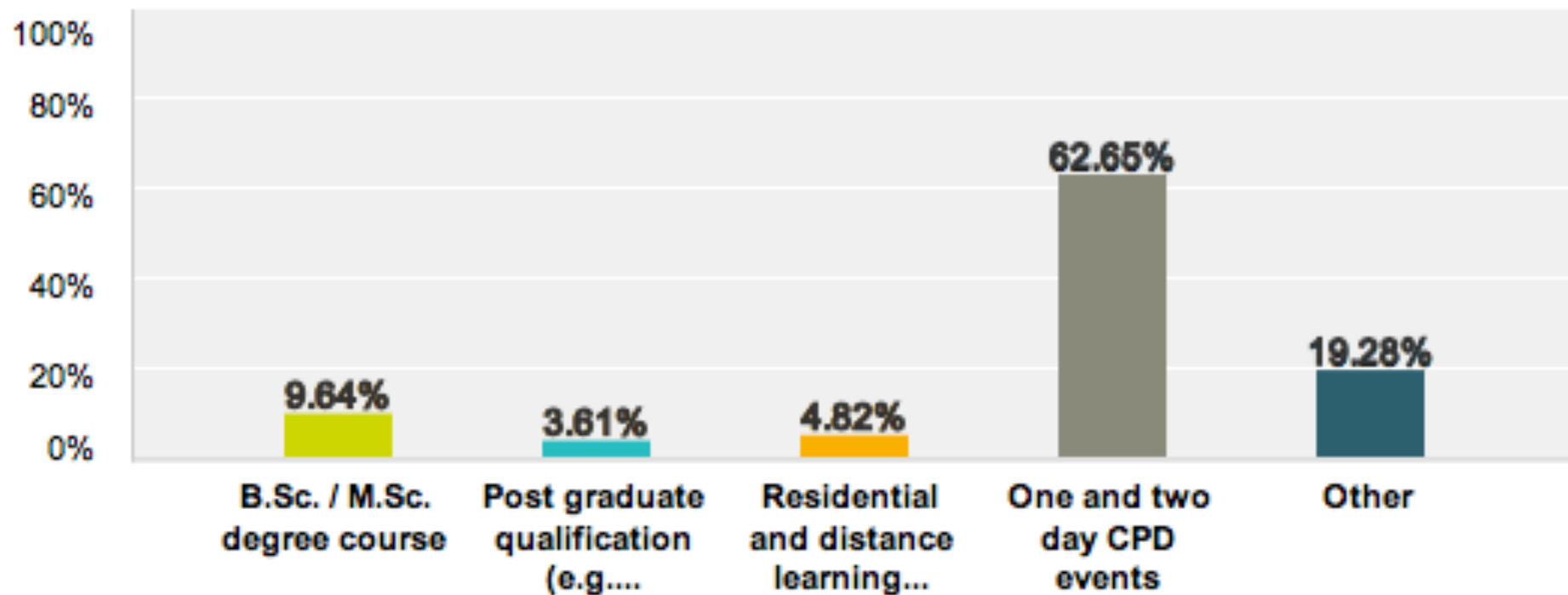

Summary of Ecological Competencies: Planners

| CIEEM Competency Themes (Type of Ecological Activity) | Basic | Capable | Accomplished | Authoritative |
|--|-------|---------|--------------|---------------|
| Ecological Surveys • Habitat identification and evaluation | 83% | 16% | 1% | 0% |
| Scientific Method • Design | 82% | 14% | 2% | 1% |
| • Implementation | 79% | 18% | 2% | 0% |
| • Analysis | 84% | 12% | 3% | 1% |
| • Interpretation and reporting | 81% | 15% | 3% | 1% |
| Environmental Management • Habitat management | 94% | 2% | 2% | 1% |
| • Habitat creation/restoration | 93% | 3% | 2% | 2% |
| • Species management | 93% | 3% | 3% | 0% |
| • Environmental compliance | 84% | 11% | 2% | 2% |
| • Biosecurity | 94% | 3% | 2% | 0% |
| Ecological Impact Assessment | 87% | 10% | 2% | 1% |
| Habitat Regulations Assessment | 89% | 9% | 1% | 1% |
| Environmental Legislation and Policy • Understanding and application | 44% | 41% | 9% | 4% |
| • Compliance and enforcement | 77% | 17% | 3% | 2% |
| Mitigation Hierarchy | 74% | 19% | 5% | 2% |

Summary of Ecological Competencies: Ecologists

| CIEEM Competency Themes (Type of Ecological Activity) | Basic | Capable | Accomplished | Authoritative |
|--|-------|------------|--------------|---------------|
| Ecological Surveys • Habitat identification and evaluation | 2% | 30% | 53% | 12% |
| Scientific Method • Design | 19% | 47% | 20% | 7% |
| • Implementation | 19% | 50% | 17% | 7% |
| • Analysis | 17% | 40% | 31% | 6% |
| • Interpretation and reporting | 9% | 43% | 37% | 7% |
| Environmental Management • Habitat management | 4% | 35% | 46% | 12% |
| • Habitat creation/restoration | 2% | 35% | 47% | 11% |
| • Species management | 2% | 30% | 49% | 15% |
| • Sustainable environmental design | 15% | 32% | 40% | 9% |
| • Environmental compliance | 9% | 35% | 35% | 16% |
| • Biosecurity | 23% | 49% | 12% | 7% |
| Ecological Impact Assessment | 4% | 36% | 39% | 18% |
| Habitat Regulations Assessment | 4% | 21% | 50% | 24% |
| Environmental Legislation and Policy • Understanding and application | 6% | 31% | 49% | 13% |
| • Compliance and enforcement | 8% | 31% | 47% | 11% |

Biodiversity Issues To Be Considered In Determining A Planning Application

(Extract from Clause 8.1 of BS42020 Biodiversity – A Code of Conduct for Planning and Development)

The decision-maker should undertake a thorough analysis of the applicant's ecological ... in reaching a decision ... should take the following into account.

- a) The soundness and technical content of ecological information;
- b) Whether biodiversity is likely to be affected and whether all potential impacts are described adequately;
- c) Whether effects are significant and, if so, capable of being mitigated;
- d) Whether the mitigation hierarchy has been applied;
- e) Whether it has been adequately demonstrated that the proposals will deliver the stated outcomes consent is granted;
- f) Whether the measures are capable of being secured through appropriate planning conditions and/or obligations and/ EPS licences;
- g) Whether the proposals are compliant with statutory obligations and policy considerations;
- h) Whether there is a clear indication of likely significant losses and gains for biodiversity;
- i) Whether any material considerations have been identified that might require changes to the application.

NOTE With regard to level of scrutiny, the British Standard recommends a proportionate approach.

The Importance of Capacity & Competence

Risks

- Failure to deliver biodiversity policy
- Failure to comply with statutory obligations
- Referral to local government ombudsman
- Expensive legal challenge through the courts (Judicial Review)
- EU Infraction proceedings (fines: £180,000 per day)
- Criminal prosecution (Aiding and Abetting) !
- Time consuming and unconstructive workloads
- Damage to local authority reputation
- Breach of RTPI Code of Professional Conduct ?

The Importance of Capacity & Competence

Are LPAs placing planners in position where they are at risk of breaching their Code of Professional Conduct?

- How do we distinguish between a planners' generalist role vs their need for specialist ecological competence?
- Clause 1 “to act competently, honestly and with integrity”;
- Clause 4 “to provide bona fide opinion/advice (i.e. advice given in good faith or to the best of their knowledge);
- Worst case scenario = if LPA's demonstrate willful disregard for statutory obligations – does this constitute breach of RTPI's CoPC on the part of a planner?

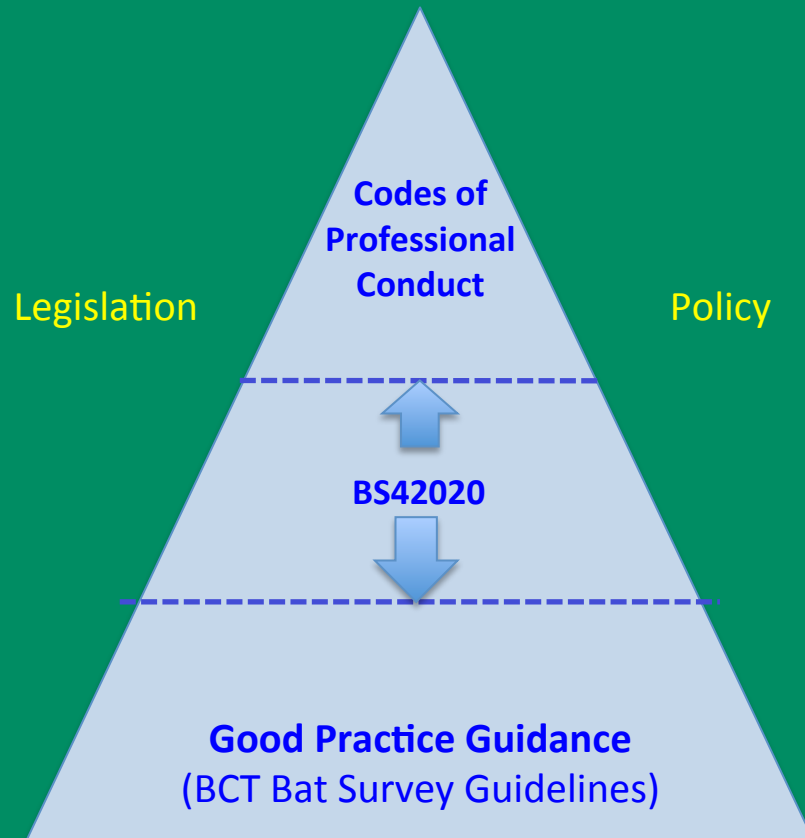

Biodiversity



Manual for Planning and Development
For all models in the BS 2012 – 2020 series

- **Owners Workshop Manual** – broken down and taken off the road
- **Roadside Repairs** – running repairs when we are travelling
- **MOT Test Checks** – statutory requirements
- **Service and Repair** – periodic routine inspection and maintenance

Thanks for your ear michaeloxford@btinternet.com